



HEAVY-DUTY LIMIT VALVES

Heavy-Duty Limit Valves



These valves feature rugged construction to withstand heavy use. A zinc alloy die cast actuator head with a hardened steel shaft in a bronze bearing is mated to a solid aluminum valve body. Inside is

a Clippard series cartridge valve (MJV-2C or 3C, MJVO-2C or 3C) made of brass and stainless steel with Buna-N seals. Valve cartridge is easily replaced in minutes. Three different style actuator arms are available as shown below.

Part No.	Description
LVA-2	2-Way Poppet Normally-Closed Limit Valve
LVA-3	3-Way Poppet Normally-Closed Limit Valve
LVAO-2	2-Way Normally-Open Limit Valve
LVAO-3	3-Way Normally-Open Limit Valve

Roller Actuator Arms

Roller Actuator Arms are ideal for Clippard heavy-duty air limit valves.

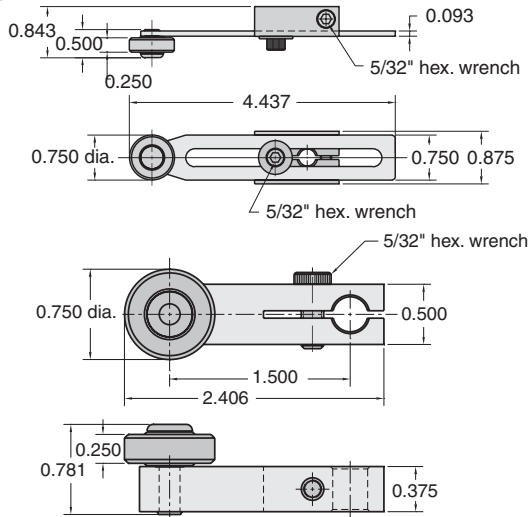

Arm: Aluminum base with steel extendable arm (AR-L only)

Roller: Hardened steel

Adjustment: AR-L only - 1.0" to 3.5"

Mounting: Slotted mounting clamp tightens onto limit valve with 5/32" hex. wrench; may be positioned on limit valve shaft in any direction within a 360° circle.

Part No.	Description
AR-K	Roller Actuator Arm
AR-L	Roller Actuator Arm, Adjustable

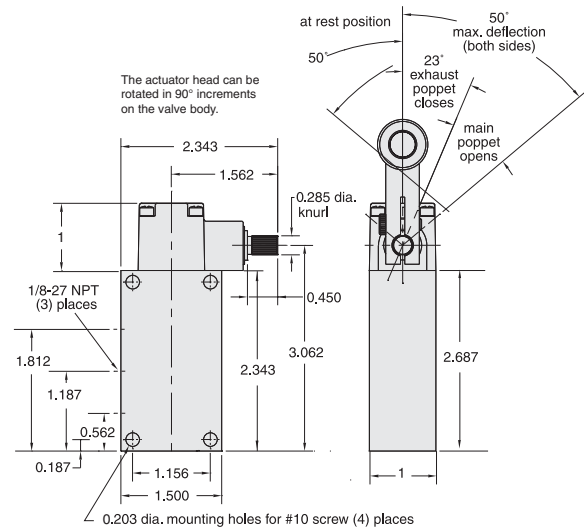

Medium: Air

Stem Travel: Actuator arm may move 50° in either direction

Input Pressure: 300 psig max.

Air Flow: 10 scfm @ 50 psig; 19 scfm @ 100 psig

Torque to Actuate: 3 in./lbs.

Actuation Range: 0 to 23° Off, 23 to 50° On, Maximum travel 50°

Mounting: Four 13/64" dia. mounting holes provided in valve body for use with #10 screw, or for tapping 1/4-20 by customer

Ports: Inlet - 1/8-27" NPT, Outlet - 1/8-27" NPT, Exhaust - 1/8-27" NPT for convenience in porting away exhaust air or attaching muffler; it should not be restricted; exhaust port is not used on 2-ways

Adjustable Rod Actuator Arm

Adjustable Rod Actuator Arm for Clippard heavy-duty air limit valves

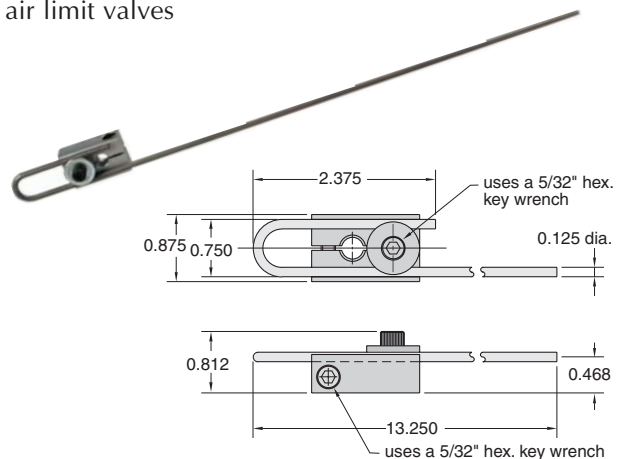

Arm: Steel 1/8" rod 13" long retained by screw clamp; the rod may be shortened and/or bent to desired shape

Mounting: Slotted aluminum mounting clamp may be positioned on limit valve shaft in any direction within a 360° circle

Part No.	Description
AR-M	Rod Actuator Arm